



TEREX

TV800-1 & TV900-1

Tandem Asphalt Rollers

OPERATING WEIGHT	3,466 / 3,572 lbs (1,572 / 1,620 kg)
NET ENGINE POWER	22 hp (16.5 kW)
STATIC LINEAR LOAD	54.2 / 56.4 lbs/in (8.7 / 10.1 kg/cm)
CENTRIFUGAL FORCE	2,809 / 2,944 lbs (12.5 / 13.1 kN)



TANDEM ASPHALT
ROLLERS

Operating Data, Standard Equipment		
	TV800-1	TV900-1
Operating weight	3,466 lbs (1,572 kg)	3,572 lbs (1,620 kg)
Basic weight	3,188 lbs (1,446 kg)	3,208 lbs (1,455 kg)
Static linear load	54.2 lbs/in (8.7 kg/cm)	56.4 lbs/in (10.1 kg/cm)
Total length	73.2 in (1,860 mm)	73.2 in (1,860 mm)
Total width	34.25 in (870 mm)	38.18 in (970 mm)
Turning radius (inside)	72.83 in (1,850 mm)	72.83 in (1,850 mm)
Total height	90.94 in (2,310 mm)	90.94 in (2,310 mm)
Frame articulation degrees	30°	30°
Frequency (Hz) VPM	2,760/3,120 (46/52 Hz)	2,760/3,120 (46/52 Hz)
Amplitude	.020 in (0.5 mm)	.021 in (0.5 mm)
Centrifugal Force lbs	2,809 lbs (12.5 kN)	2,944 lbs (13.1 kN)
Gradeability % (with vibration on)	30%	30%
Gradeability % (with vibration off)	40%	40%
Drum thickness	.4 in (10 mm)	.4 in (10 mm)

Tandem Asphalt Rollers

TV800-1 & TV900-1

Specifications

Engine	
Manufacturer, model	Kubota, D905
Type	3-cylinder, diesel engine
Power rating at 2,500/3,000 rpm	22 hp (16.5 kW)
Cooling system	Liquid
Electrical System	
Nominal voltage	12 Volt
Battery	770 CCA
Alternator	65 Amp
Hydrostatic Transmission	
Hydrostatic drive. Forward and reverse selected from joystick. Infinitely variable speed control forward and reverse. 0 – 5 mph (0 – 8.0 km/h)	
Drive	
Dual radial piston drive motors.	
Brakes	
Service brake: Hydrostatic drive provides dynamic braking.	
Parking brake: Spring applied failsafe	
Steering	
Heavy duty articulated steering	
Fluid Capacities	
Fuel tank	4.75 gal (18 L)
Hydraulic system (includes tank)	7.4 gal (28 L)
Water tank	22.7 gal (86 L)
Operator's Area	
Open operator's compartment with functional design, excellent all-around visibility and user-friendly operator controls.	
Operator's suspension seat with hydraulic cushioning and lap belt; weight, height and longitudinally adjustable.	

Standard Features

Vandal protection package
Back-up alarm
2 spring loaded scrapers per drum
Hydraulic test points
Electrical diagnostics system (LED lights)
Tow valve
12 volt battery disconnect
Pressure and gravity water
ROPS

Optional Features

Folding ROPS
Factory-installed hydraulic hammer includes hammer, valve, hoses and tools.

Dimensions

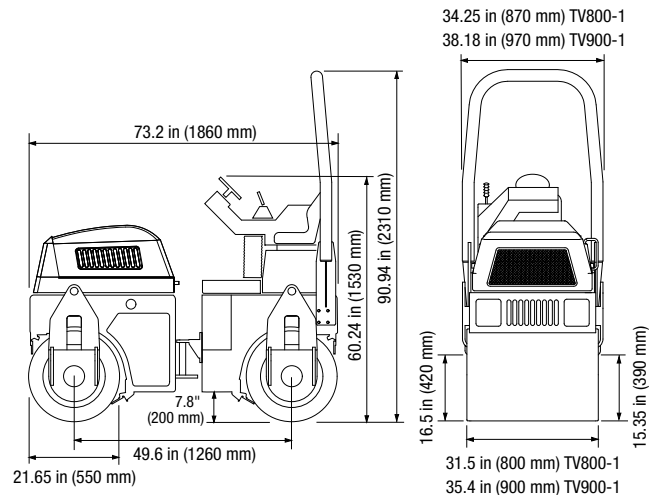

TEREX Construction Americas

8800 Rostin Road
Southaven, MS 38671
USA

TEL 662-393-1800
SALES 866-837-3923
PARTS & TECH SUPPORT 888-201-6008
FAX 662-393-1700
EMAIL sales@terexca.com
WEB terexca.com

For more information, product demonstration, or details on purchase, lease and rental plans, please contact your local TEREX Distributor.

Effective date: January 1, 2005. For further information, please contact your local distributor or the TEREX sales office listed. Continuous improvement of our products is a TEREX policy. Product specifications are subject to change without notice or obligation. The photographs and drawings in this brochure are for illustrative purposes only. Refer to the appropriate Operator's Manual for instructions on the proper use of this equipment. Failure to follow the appropriate Operator's Manual when using our equipment or to otherwise act irresponsibly may result in serious injury or death. Prices and specifications subject to change without notice. The only warranty applicable is the standard written warranty applicable to the particular product and sale. TEREX makes no other warranty, expressed or implied. Products and services listed may be trademarks, service marks or trade-names of TEREX Corporation and/or its subsidiaries in the USA and other countries and all rights are reserved. "TEREX" is a Registered Trademark of TEREX Corporation in the USA and many other countries. Copyright ©2005 TEREX Corporation

TV800-1/TV900-1 2.5K 0105B Part #109038